



APRON WEIGH FEEDER

AUMUND WEIGH FEEDER TYPE DPB

Through the combination of the proven technique of AUMUND pan conveyors and the acknowledged process weighing electronics in one unit, the AUMUND Weigh Feeder performs two operations in one single step:

- **Reclaim and Weighing**

To obtain a product of consistent quality, the production process requires proportional feeding of the raw materials.

The Weigh Feeder especially designed for this purpose features an integrated weighing rail combined with the electronics processing the measured data and ensures gravimetric proportioning with the desired precision.

With the flexible geometry of AUMUND pan conveyors adapting to any kind of bulk materials, the Weigh Feeder is suitable for a large variety of applications requiring proportional feeding.

The AUMUND Deep-Drawn Pan Conveyor type KZB provides the geometry suitable for coarse bulk materials with fines such as

- **Clinker**
- **Granulated blast furnace slag**
- **Petroleum coke**

The deep-drawn pan version of the AUMUND Weigh Feeder is recommended, for example, whenever proportional feeding of clinker into the cement mill is required. For mill feeding either on the raw material or the cement side, the Weigh Feeder is also available as enclosed and pressure-tight unit.

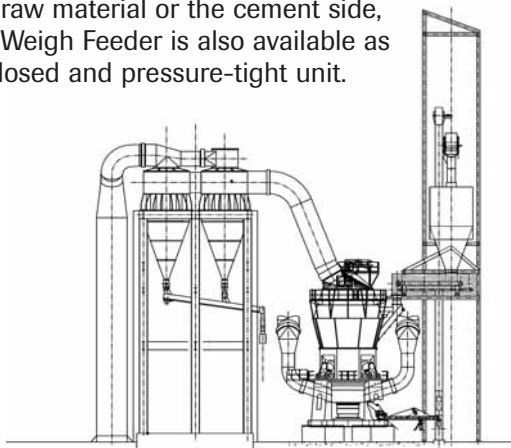

Weigh Feeder type DPB



Weighing rail

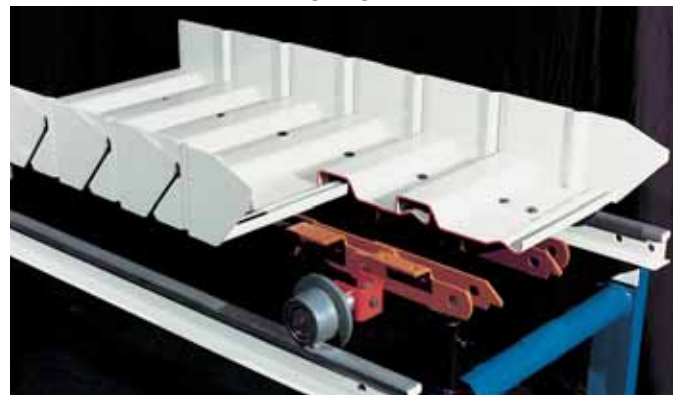

Deep-Drawn Pan Conveyor type KZB



ONE MACHINE - TWO STEPS

For proportional reclaim of bulk materials with poor flow properties such as

- Clay
- Gypsum
- Marl
- Limestone
- Puzzolana etc.

The measured data is memorized by the electronic unit and subsequently processed and transferred to the frequency converter. The drive unit regulates the conveying speed to achieve the desired reclaim rate.

the AUMUND Arched Plate Conveyor type BPB with its curved plates especially designed for cohesive products is the adequate solution.

Deep-Drawn Pan Conveyor or Arched Plate Conveyor, the AUMUND Weigh Feeder offers the definite advantage of combining two steps of the production process in one single machine.

The weighing rail integrated into the conveyor track next to the drive station controls the actual discharge rate.



Weigh Feeder type DPB



Arched Plate Pan Conveyor type BPB

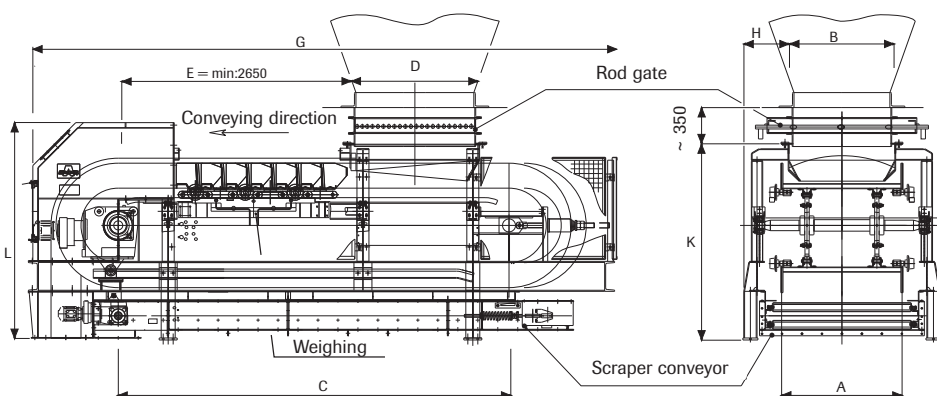

Pan width/ height	Weigh feeder dimensions (mm)				
	800 / 200	1.000 / 200	1.200 / 200	1.400 / 200	1.600 / 200
A	800	1.000	1.200	1.400	1.600
B	600	800	1.000	1.200	1.400
C	4.350	4.750	5.150	5.550	5.950
D	1.200	1.600	2.000	2.400	2.800
E	2.650	2.650	2.650	2.650	2.650
G	6.260	6.660	7.060	7.460	7.860
H	450 - 600	450 - 600	450 - 600	450 - 600	450 - 600
K	1.960	1.960	1.960	1.960	1.960
L	2.180	2.180	2.180	2.180	2.180

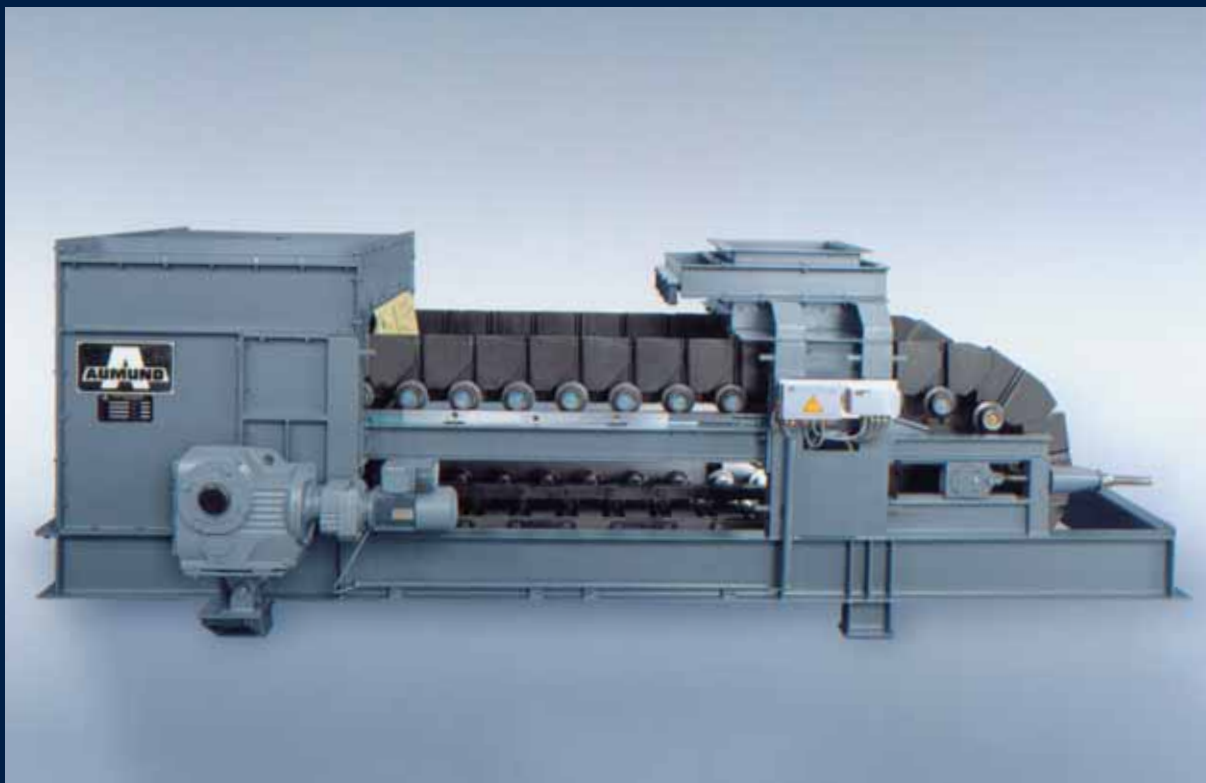

Weigh Feeder type DPB-B



Weigh Feeder type DPB-B

www.aumund.com