

Available in three sizes : 60, 200 and 400



FLOWRIT

- ✓ Accuracy better than 1 %
- ✓ Feedrate from 3 t/h to 400 m³/h
- ✓ Two digital load cells
- ✓ On line automatic taring system
- ✓ Long lasting reliability
- ✓ Easy maintenance
- ✓ Free flow of material

Feeding & Metering:
Fly ash,
Ground slag,
Filter dust,
Raw meal, etc.



FLOWRIT 60



FLOWRIT 200 open
without settling chamber



FLOWRIT 400
with settling chamber

Function:

Measures:

Channels 1 and 2 are both equipped with a digital load cell. The first one measures the force (F_R) acting perpendicularly on the chute, and the second evaluates the speed (F_P).

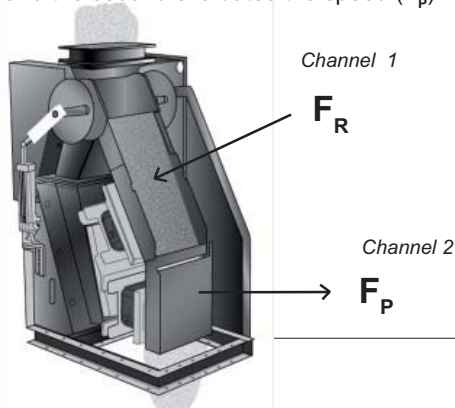

Regulation:

The informations obtained allow the controller to calculate and to drive the mechanical part which regulates the incoming flow according to the setpoint.

* SCM2 : Field or Panel version:
see SCM2-F.260.001-E. or
SCM2-P.260.001-E.



SCM2-Panel



SCM2-Field

The unique FLOWRIT BY-PASS:

The BY-PASS diverts the material through the by-pass channel to allow, first the blowing cleaning of the first weighed channel, and secondly, the automatic zero calibration of the measuring channels during normal production.

The BY-PASS valve is pneumatically activated and the calibration frequency is programmable in the controller.

The zero calibration is carried out during normal production and operating conditions, without flowrate interruption.

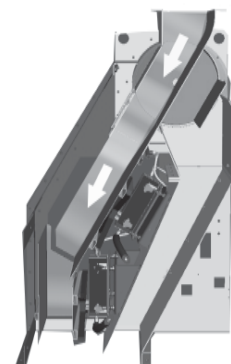

BY-PASS position for
flowrate measurement

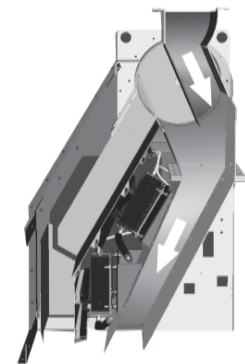

By-PASS position for
on line zero calibration

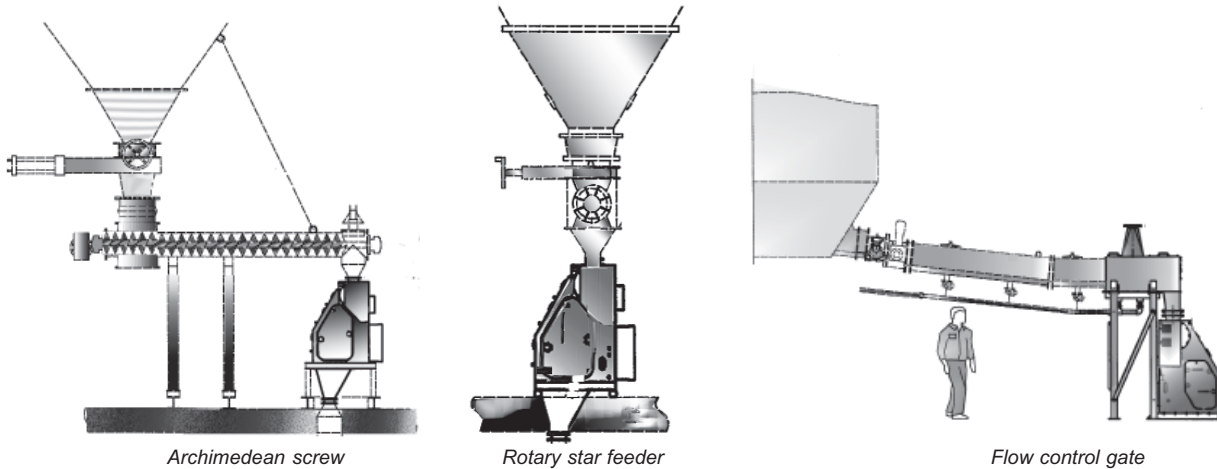
Examples for FLOWRIT feeding

Archimedean screw
Rotary star feeder
Flow control gate
The settling chamber

Available for Flowrit 200 and 400 it conditions the material speed and flow behavior at the FLOWRIT inlet.

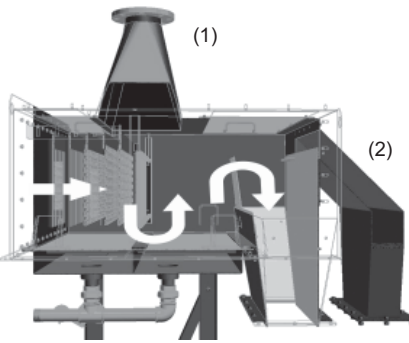
Chains and rakes favor the removal of the air in the material which is then conditioned by adjustable gates and a siphon type labyrinth. From there, it overflows and enters the measuring channels from a clearly defined height and without any initial horizontal speed.

Settling chamber (side view)

The degasification catch (1) evacuates air in the upper part.

A pressure balancing sheath (2) balances the pressure in the measuring compartment.

Technical Details
Material of construction for By-Pass and Measuring Channels:

Stainless Steel AISI 316

Material of construction or the lining of parts in contact with the material may vary as a function of the application. (ie : highly abrasive materials).

Compressed air supply requirement: 6 to 10 bars, R1/4"

All pneumatic devices (pressure reducers, pressure gauges and distributors,...) are mounted on a single panel at the back of the FLOWRIT.

Temperatures:

- +60 °C < T < 120 °C high temperature version
- 0 °C < T < 60 °C standard version

Protection class for electrical components on the FLOWRIT: IP65
Dimensions and flowrate range:

Model	Length mm	Width mm	Height mm	Weight Kg	Inlet Cross Section mm	Outlet Cross Section mm	Flowrate range
FLOWRIT 60	740	560	1440	200	L 114 x w 233	-	3 t/h to 60 m ³ /h max
FLOWRIT 200	1600	850	2200	650	L 300 x H 350 max	L 400 x w 556	15 to 200 m ³ /h max
FLOWRIT 400	1880	1260 to 1660	3100	1200-1500	L 550 x H 340 max	L 490 x w 860	30 to 400m ³ /h max

(Dimensions including settling chamber)

HASLER International SA
 Z.I. de L'Abbaye
 F-38780 Pont-Evêque France
 Tel. +33 (0)4 74 16 11 50
 Fax +33 (0)4 74 16 11 55
 E-mail: sales.fr@hasler-int.com

HASLER Deutschland GmbH
 Münsterstrasse 69
 D-49525 Lengerich Germany
 Tel. +49 (0)5481 805-0
 Fax +49 (0)5481 805-110
 E-mail: sales.de@hasler-int.com

HASLER Suisse Sàrl
 Rue du Puits-Godet 10a
 CH-2000 Neuchâtel Switzerland
 Tel. +41 (0)32 720 23 00
 Fax +41 (0)32 720 23 90
 E-mail: sales.ch@hasler-int.com

HASLER Industrial Equipmt Shanghai Co. Ltd
 541 Deli Road - Malu Town
 Jiading District
 CN - 201801 Shanghai P.R. China
 Tel. +86 21 5910 6058
 Fax +86 21 5910 5300
 E-mail: sales.cn@hasler-int.com