



**CLAUDIUS PETERS**  
TECHNOLOGIES



# Pneumatic Conveying Technik

FLUIDCON



**Technology you can trust**

[www.claudiuspeters.com](http://www.claudiuspeters.com)

## Claudius Peters FLUIDCON ...

### About

*Claudius Peters Technologies GmbH, Germany and Claudius Peters Technologies S.A., France are part of the technologies division of Claudius Peters Group GmbH. The corporate headquarters is in Buxtehude, Germany, near Hamburg, which offers technologies in the field of materials handling and processing, providing turnkey and semi-turnkey systems to a wide range of industries. Claudius Peters Group GmbH is wholly owned subsidiary of Langley Holdings plc, a privately controlled UK engineering group, with regional offices in the Americas, Europe, China and the Far East.*

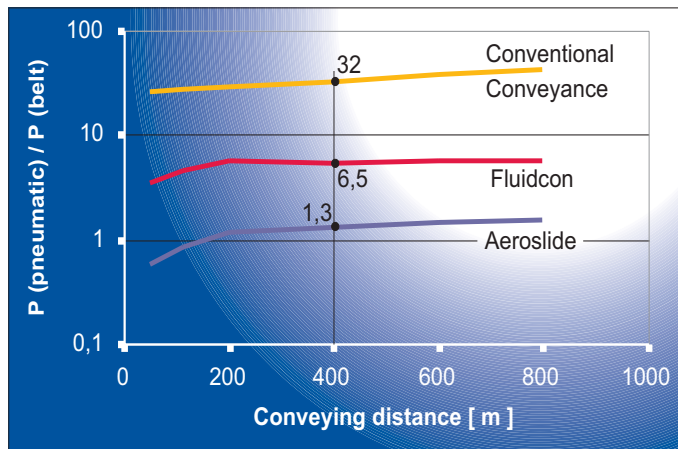

Pneumatic conveying has always been an acceptable means for transporting fine materials from one location to the other. From a positive point of view, the initial investment and maintenance costs are typically lower when compared to mechanical conveying systems.

The energy consumption for the air supply on conventional pneumatic systems is considerably higher compared to the power requirements of alternative systems

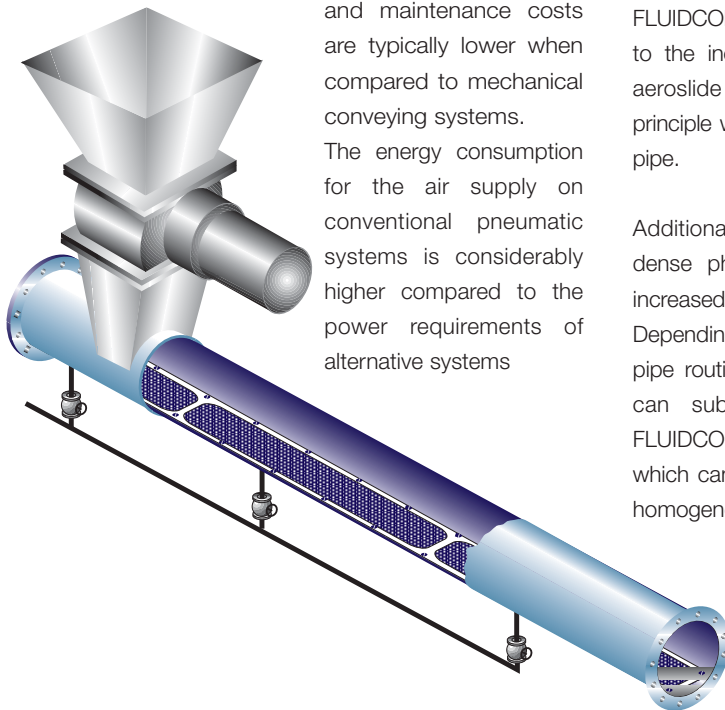

The Claudius Peters FLUIDCON system utilizes the advantages of typical pneumatic conveying at considerably lower energy requirements.

FLUIDCON has the benefits of less power consumption due to the incorporation of the aeroslide transportation principle within the transport pipe.

Additionally, it provides a dense phase system with increased bulk material load. Depending on the transport pipe routing, the new Claudius Peters FLUIDCON system can substantially reduce power consumption. The FLUIDCON system can be used to convey all fine bulk solids which can be fluidized with low air velocities, and expands homogeneously during the process.



... is there a better conveying technique?

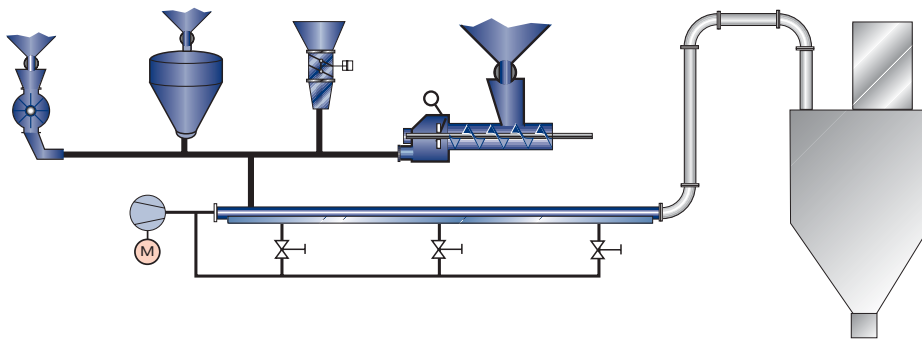

### FLUIDCON

is a conveyor pipe that can be partially or completely fluidised over the horizontal length of the pipe (the aeroslide principle). This air is used to fluidise but not transport the material.

The material transport air

travels perpendicular to the fluidisation air (the conveyor pipe principle) and passes in an axial direction. The pressure loss of the transport air flow substitutes for the inclination of an aeroslide. The Aeroslide Principle turns the bulk solids into a fluid state with minimal internal friction and insures that the solids remain fluidised away from the bottom of the pipe and into the gas flow. These optimum conveying conditions allows the transportation of solids with lowest axial driving gas velocities in the feed point and acceleration section of the pipe. Therefore, it is possible to convey materials with minimal differential pressure and inclined uphill up to 30° with the FLUIDCON system.

### Advantages of FLUIDCON

- **Reduced operating costs** - substantially less energy consumption compared to conventional pneumatic conveying.
- **High availability** - the system is easily started or re-started even when solids remain in the conveying line.
- **Gentle Material handling** - this is due to lower conveying velocities starting at approximately 2-3 m/s and ending at approximately 5 - 10 m/s.
- **Alternative feed systems** - with a reduction in the conveying pressure, Claudius Peters X-pumps (screw pumps) can be installed instead of conventional pressure vessels to insure savings in height and capital costs.



FLUIDCON  
transport system  
at Holcim plant Lägerdorf  
for 230 t/h cement





# Claudius Peters FLUIDCON

..... there is no better system

The FLUIDCON System has proven to be a valuable alternative in bulk materials handling applications. Additionally this type of system can be utilized in ash removal plants. This system is particularly suitable for the removal of fly ash from a baghouse or ESP. The fly ash discharge points are connected to a common FLUIDCON conveying pipe and the ash is continuously removed and can be conveyed long distances. The application of the FLUIDCON system for the conveying of dust below filter installations offers the following advantages compared to other conveying installations:

- Lower investment cost
- Lowest gas and solids velocities
- Lowest conveying pressure
- Lowest wear
- Lowest power requirements
- Lower installation height
- Simplified material feeding

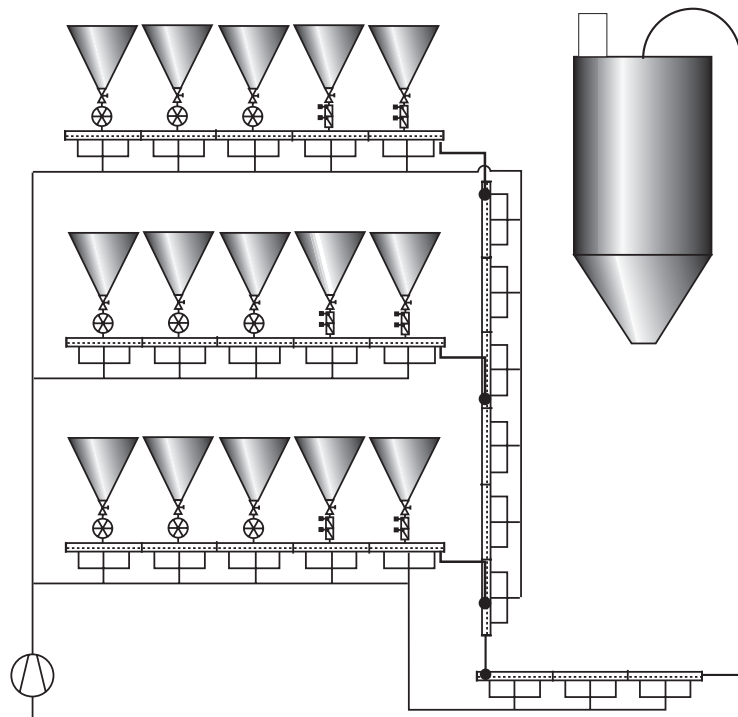

FLUIDCON transport system  
at E-on Farge Plant

CALCINING . COATING  
 COOLING . DISPATCH  
 DOSING . DRY BLENDING  
 DRYING . GRANULATION  
 GRINDING . PACKING  
 PNEUMATIC CONVEYANCE  
 PULVERISED FUEL SUPPLY  
 SILO SYSTEMS  
 STOCKYARD SYSTEMS  
 TURNKEY PROJECT



**CLAUDIUS PETERS  
 TECHNOLOGIES**

A Langley Holdings Company

**Claudius Peters Technologies GmbH**  
 Schanzenstraße 40  
 D-21614 Buxtehude Germany  
 Tel. +49 (0) 4161 706 0  
 Fax +49 (0) 4161 706 270  
[technologies@claudiuspeters.com](mailto:technologies@claudiuspeters.com)

LOCAL OFFICE

[www.claudiuspeters.com](http://www.claudiuspeters.com)

The information contained within this brochure is deemed to be correct at the time of going to press. Due to the policy of continued improvement, we reserve the right to change any specification without prior notice. ERRORS & OMISSIONS EXPECTED